

# IMPLEMENTATION OF AN EXTREMUM SEEKING CONTROLLER IN A UASB-REACTOR

*4th Frech-Chilean Workshop on Bioprocess Modeling*

**Manuel Ble**  
Electronic Engineer  
Universidad de Guanajuato, México.

September 22, 2016



# OUTLINE

- I. Problematic
- II. Justification
- III. System modeling
- IV. Results
- V. Test robust
- VI. Future work
- VII. References

# PROBLEMATIC

As a renewable and clean energy carrier, **methane**, obtained from the anaerobic biodegradation of waste is **an emerging technology** with a **high potential** to help addressing **the current energetic** an environmental problem [3].

The objective of this work is to **implement** an **optimization strategy on-line**, through the Extremum Seeking Control to **maximize methane production** in a **UASB reactor** (Upflow Anaerobic Sludge Blanket) of an anaerobic process applied in the **wine** industry.

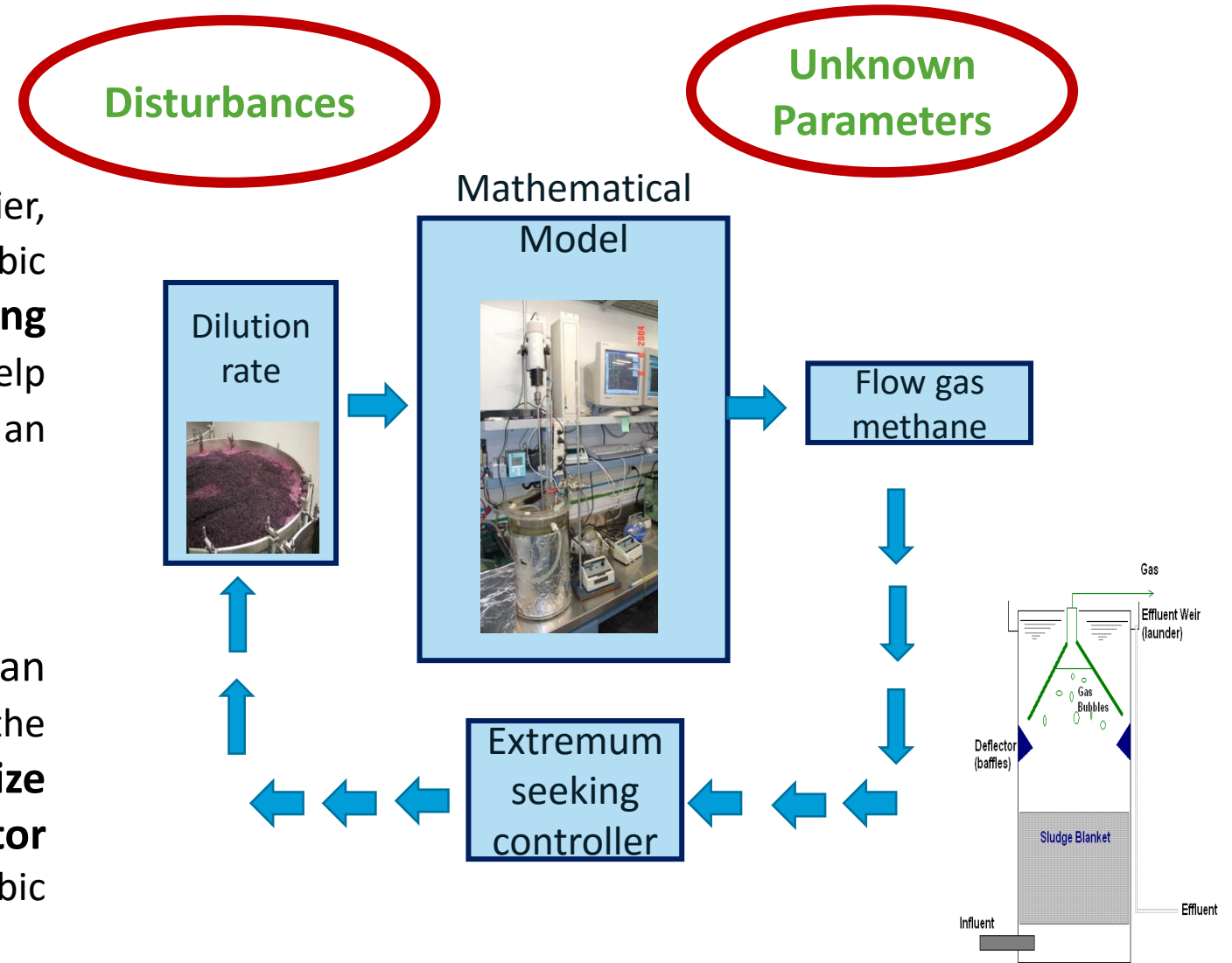

# JUSTIFICATION

- Applicable in situations where there is a non-linearity in the control problem and the **nonlinearity** has a **local minimum** or **maximum** [2,4].
- On-line optimization.
- Not based on the mathematical model.
- Maximum level methane production rate.
- **Robustness** of the disturbance models.

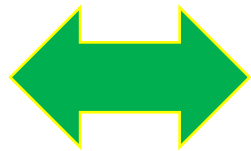

FREE SOFTWARE

## Dynamic model of a continuous stirred tank reactor.

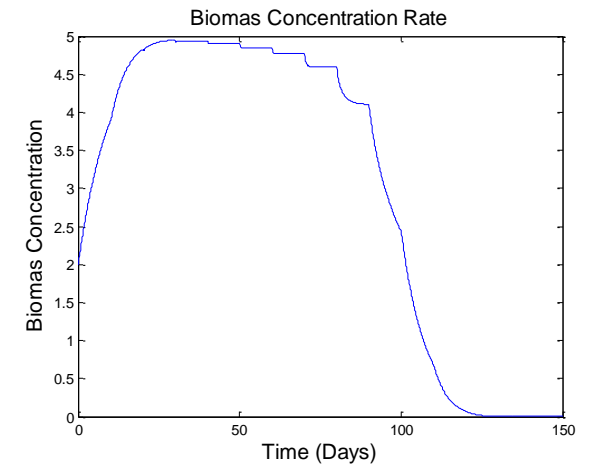
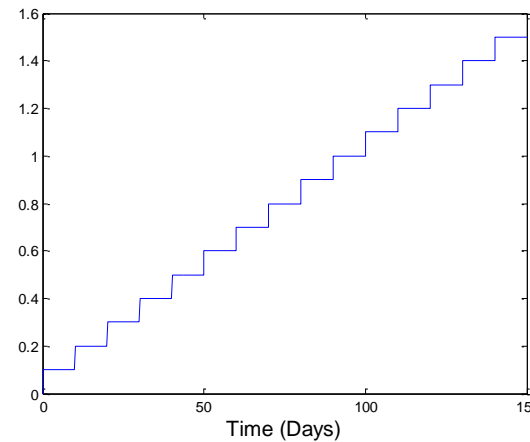

### Biotechnological Process

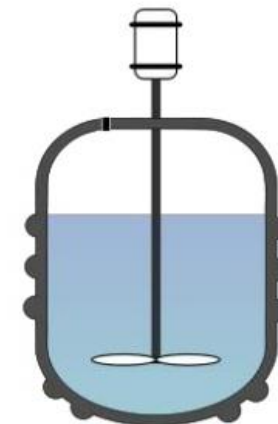

# SYSTEM MODELING

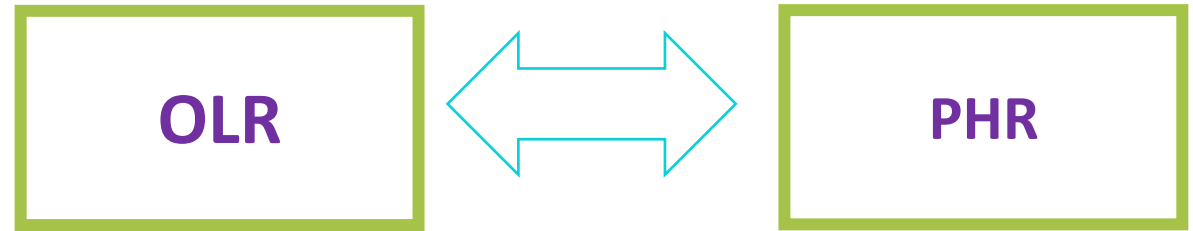

## ➤ STATIC MAP

*On-line heuristic optimization strategy to maximize the hydrogen production rate in a continuous stirred tank reactor.*

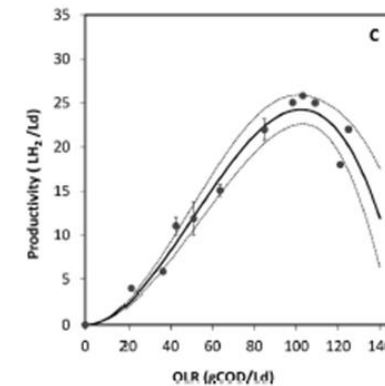
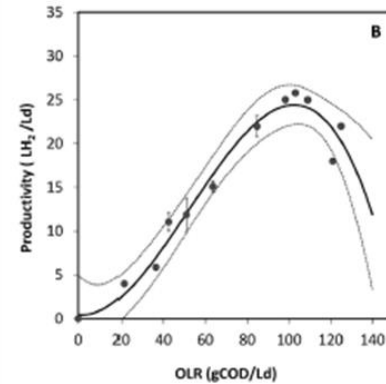
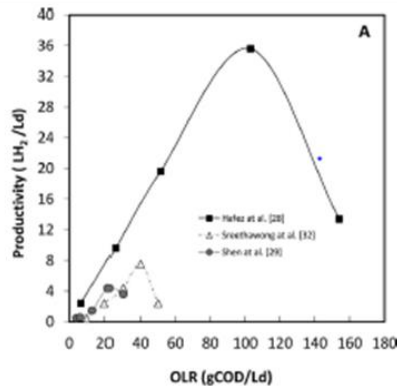

## ➤ DYNAMIC MAP

- a) Anaerobic Digestion Model No.1 (**ADM1**) by Rosen, C. and Jeppson, U. reference BSM2 [2].
- b) 35 state variables. ( Biomass, Sugar, Flow Gas)
- c) **Parameters** kinetics and physic-chemistry and Biochemistry



Find an input optimal

Maximize HPR

ESC Improve

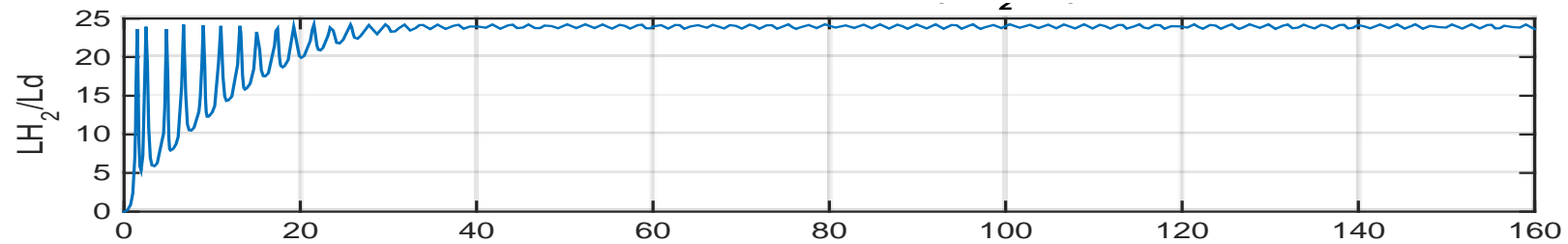
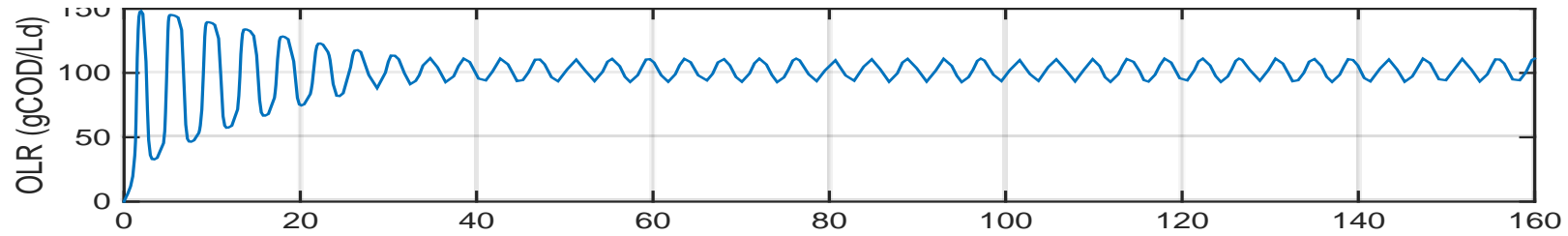
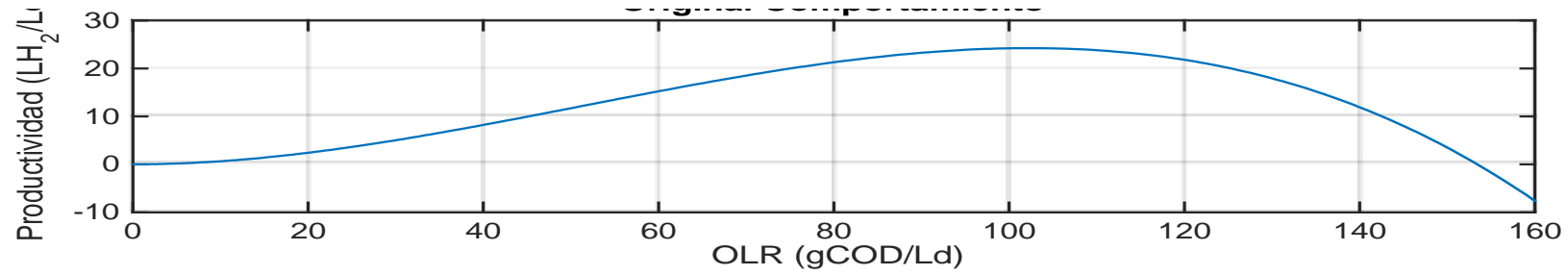

# EXTREMUM SEEKING CONTROL VIA THE DILUTION RATE

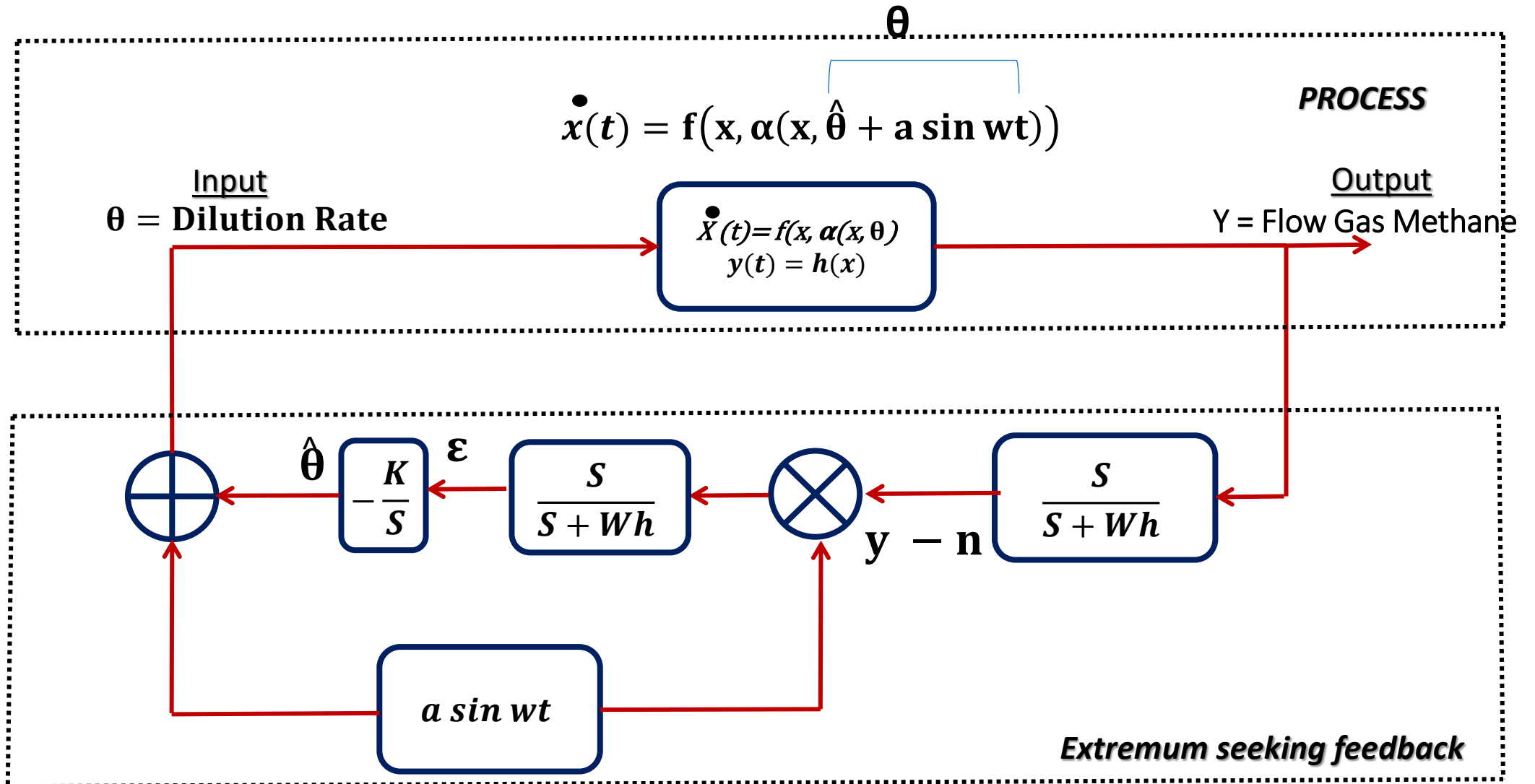

# RESULTS. Law close-loop

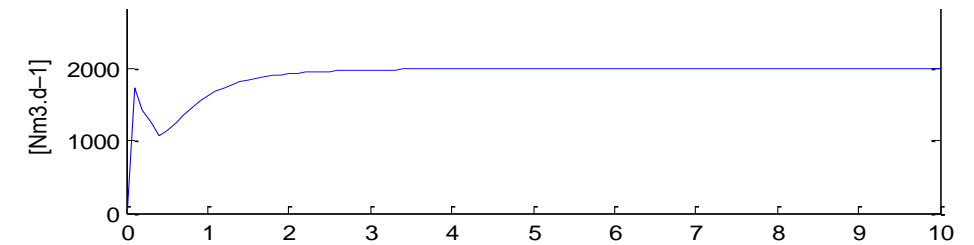
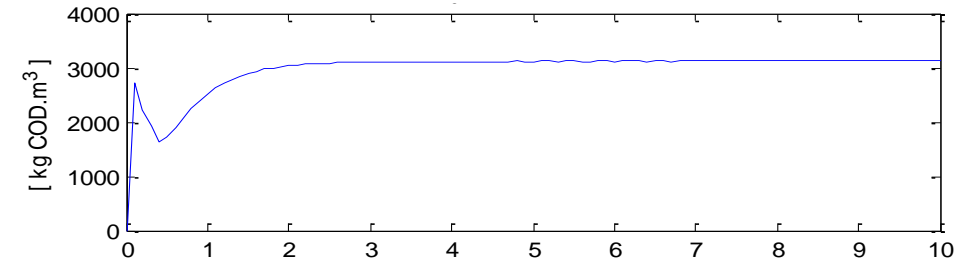
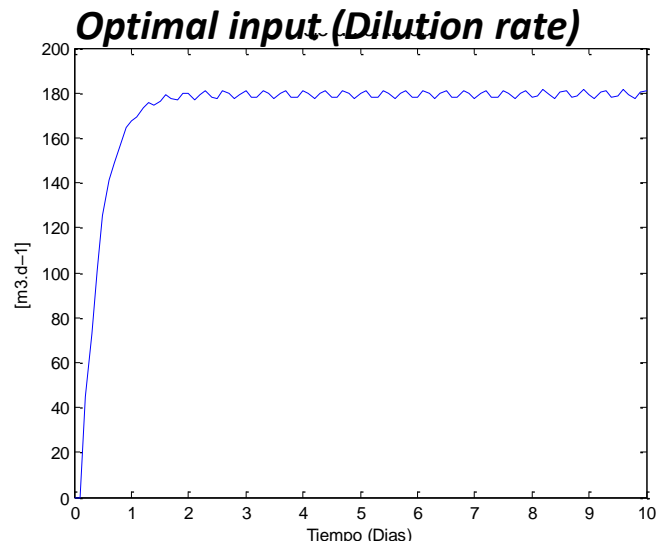

**Optimal output (Flow gas total and Flow gas methane)**

**Extremum  
seeking  
controller**

# TEST ROBUST

White noise to the output variable.

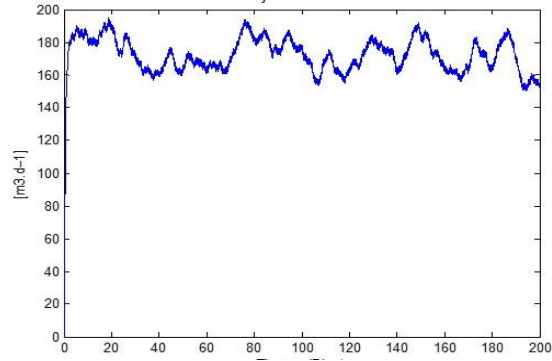

Variation of the Chemical Oxygen Demand. (Disturbance)

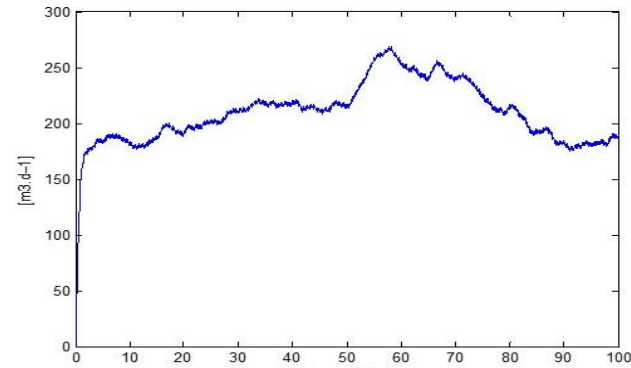

Variation of the kinetic parameters.

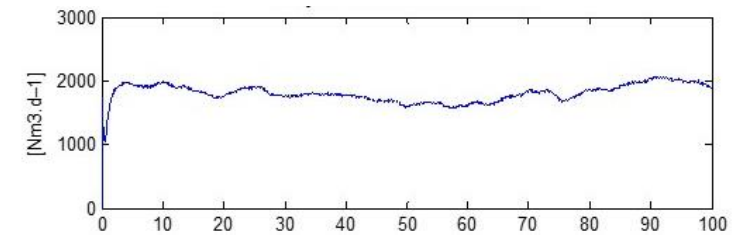
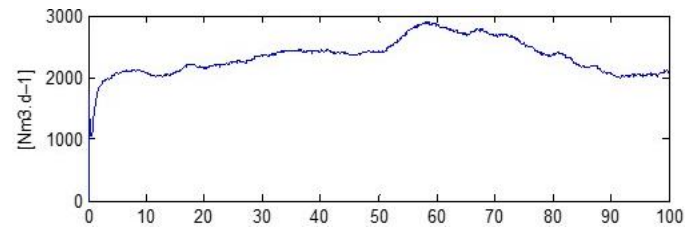
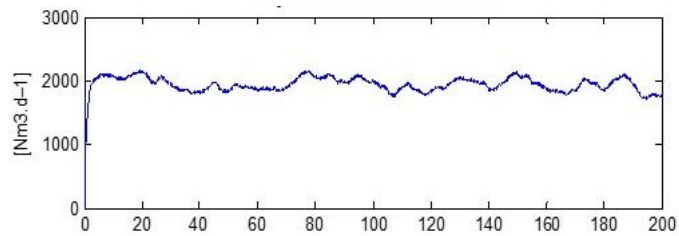
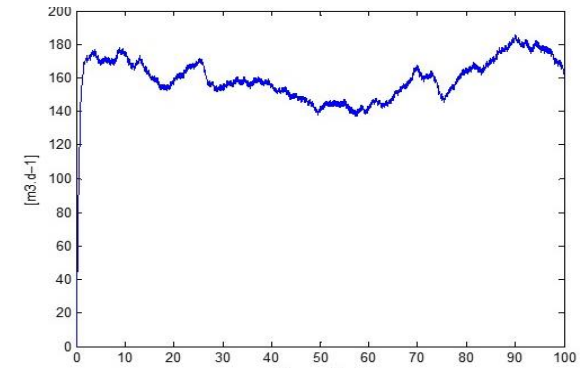



# REFERENCES

- [1] R. Rodríguez and G. TRACONIS, “Gestión ambiental de la vitivinicultura: aplicación del cuadro de mando,” *Econ. Gest. Desarro. Cali (Colombia)*, no. 13, pp. 93–119, 2012.
- [2] D. J. Batstone, J. Keller, I. Angelidaki, S. Kalyuzhnyi, S. Pavlostathis, A. Rozzi, W. Sanders, H. Siegrist, and V. Vavilin, “The iwa anaerobic digestion model no 1 (adm1),” *Water Science and Technology*, vol. 45, no. 10, pp. 65–73, 2002.
- [3] H.-S. Jeong, C.-W. Suh, J.-L. Lim, S.-H. Lee, and H.-S. Shin, “Analysis and application of adm1 for anaerobic methane production,” *Bioprocess and biosystems engineering*, vol. 27, no. 2, pp. 81–89, 2005.
- [4] K. B. Ariyur and M. Krstic, *Real-time optimization by extremum-seeking control*. John Wiley & Sons, 2003.
- [5] J. E. Ramírez-Morales, I. T. Zúñiga, and G. Buitrón, “On-line heuristic optimization strategy to maximize the hydrogen production rate in a continuous stirred tank reactor,” *Process Biochemistry*, vol. 50, no. 6, pp. 893–900, 2015.
- [6] I. T. Zúñiga, A. Vargas, E. Latrille, and G. Buitrón, “Robust observation strategy to estimate the substrate concentration in the influent of a fermentative bioreactor for hydrogen production,” *Chemical Engineering Science*, vol. 129, pp. 126–134, 2015.